

Price list

National Centre for Biotechnology Education

Microbiology

NEW Synthetic biology kit

Synthetic biology and genetic engineering are part of A-level biology courses. Our synthetic biology kit allows students to experience this part of the syllabus as a practical, in a controlled and safe way. Students will choose whether to make red or green fluorescent bacteria, use restriction enzymes to cut out their fluorescent gene of choice and then use ligase to insert this into a second plasmid. This will be transformed into bacteria and the spectacular results can be visualised the following day using UV torches. The practical is very flexible and can be taught in one go or split up over several lessons. In addition to making the genetic engineering section of the A-level course practically accessible, this kit would also be suitable for science clubs or extension activities for 16-18 year olds. The kit contains sufficient materials for 16 pairs or groups of students.

Synthetic biology kit£180.00

Replacement parts AS PROVIDED IN THE KIT

Slope culture of *Escherichia coli* STRAIN DH10B £19.00
 LB agar (1 sachet) + IPTG and Kanamycin..... £23.10
 Plasmids and transformation buffer (2 tubes of each).....£27.30
 Restriction enzymes + ligase as in kit..... £54.00
 Ultraviolet keyring torches, 2 £10.50
 Students' guides, 8*£14.00
 Teacher and technicians' guides, 2.....*£11.00
 Long white graduated tips (100).....£14.00

* Zero-rated for VAT.

Bacterial transformation kit

This kit gives safe practical experience of one of the key techniques used in genetic modification, by transforming bacteria with a gene encoding green fluorescent protein. It also provides an opportunity for students to understand and carry out some basic microbiological techniques. The kit contains sufficient materials for 18 students working individually. Suitable for GCSE, A Level and equivalent courses.

Bacterial transformation kit£92.00

Replacement parts AS PROVIDED IN THE KIT

Slope culture of *Escherichia coli* STRAIN DH10B £19.00
 Transformation buffer (CaCl₂) + plasmid DNA £25.00
 LB agar (1 sachet) + IPTG and Kanamycin..... £23.10
 Ultraviolet keyring torches, 2 £10.50



For safety reasons the synthetic biology and bacterial transformation kits are not generally available outside the UK (please ask for details).

Oyster mushroom starter culture

Pleurotus ostreatus, the oyster mushroom, was cultivated on waste material in Germany as a subsistence measure during World War I. This 'spawn' allows you to grow oyster mushrooms on an artificial log using 'bathroom stationery' or a roll of paper towels. The production of fruiting bodies is triggered by a cold shock (placing the toilet roll in the fridge) a week or two after the initial inoculation. Can be used as a stimulating introduction to the carbon cycle, lending itself to open-ended investigations e.g., the effect of light, temperature and humidity on fruiting. This pack contains sufficient 'spawn' for cultivating mushrooms on at least 10 standard-sized toilet rolls.

Oyster mushroom starter, 500g*£26.25

* Zero-rated for VAT.

Microbial fuel cell

This microbial fuel cell is ideal for investigations of respiration. The cell can be used with baker's yeast to generate electricity (0.4–0.6V; 3–50 mA). It comes with neoprene gaskets, electrode material, cation exchange membrane and instructions. Additional chemicals are required (phosphate buffer, methylene blue, glucose and potassium hexacyanoferrate III).

Microbial fuel cell £70.00

Replacement parts AS PROVIDED WITH THE CELL

Electrode material.....£9.50
 Cation exchange membrane, 50 x 50mm £13.65

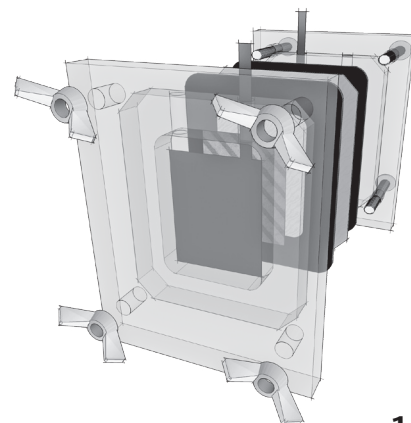

2022 **Microbial slope**

| Organism | Grows on | Educational use/interest |
|--|--|--|
| <i>Bacillus subtilis</i> | Nutrient agar. | Makes several extra-cellular enzymes: amylase, lipase and cellulase. Produces a surface pellicle if grown in broth, so not ideal if making pour plates. |
| <i>Cellulomonas</i> sp. | Nutrient agar or CMC agar. | Produces extracellular cellulase. |
| <i>Escherichia coli</i> Lac + | Nutrient or LB agar or broth. | Makes β -galactosidase when induced by lactose in the growth medium. |
| <i>Escherichia coli</i> Lac - | Nutrient or LB agar or broth. | Lacks the gene encoding β -galactosidase. |
| <i>Escherichia coli</i> STRAIN HT-99 | Nutrient or LB agar or broth. | Harbours a plasmid that includes a gene conferring resistance to chloramphenicol. 'Mated' with J53-R, it can be used to demonstrate bacterial conjugation. |
| <i>Escherichia coli</i> STRAIN J53-R | Nutrient or LB agar or broth. | Carries a chromosomal gene conferring resistance to the antibiotic rifampicin. 'Mated' with HT-99, it can be used to demonstrate bacterial conjugation. |
| <i>Escherichia coli</i> STRAIN DH10B | Nutrient or LB agar or broth. Incubate at 37°C. | For transformation [see 'Bacterial transformation kit' on page 1]. |
| <i>Escherichia coli</i> STRAIN B | Nutrient or LB agar or broth. | For infection with T4 bacteriophage [see page 1]. |
| <i>Janthinobacterium lividum</i> | Nutrient agar or broth with 1% (w/v) glucose added. Grows best at 20°C. Needs frequent subculturing. | Produces a dark purple pigment when the density of the cells is sufficient or other Gram-negative species are present — an example of quorum sensing. |
| <i>Micrococcus luteus</i> | Nutrient agar or broth. | Yellow coloured-colonies; model organism to test against antimicrobials such as disinfectants. |
| <i>Micrococcus roseus</i> | Nutrient agar or broth. | Pink coloured-colonies; model organism to test against antimicrobials such as disinfectants. |
| <i>Pectobacterium carotovorum</i> (= <i>Erwinia carotovora</i>) | Nutrient agar or broth. (Egg yolk agar can also be used to show lipase activity.) | Makes pectinase, causing 'soft rot' of fruit. Can be used to demonstrate 'Koch's postulates'. Also makes lipase. |
| <i>Streptomyces griseus</i> | Nutrient agar with 1% glucose added. | This strain makes extracellular Streptomycin. |
| <i>Vibrio natrigens</i> | Nutrient agar with 2% (w/v) sodium chloride added. | The fastest-growing microbe known. Grow in saline nutrient broth at 37°C to produce growth curves. |

| Organism | Grows on | Educational use/interest |
|--|---|---|
| <i>Kluyveromyces lactis</i> | Malt agar or glucose nutrient agar. | Unlike <i>Saccharomyces</i> spp., <i>K. lactis</i> makes the enzyme β -galactosidase and can therefore metabolise lactose. |
| <i>Neurospora crassa</i> | Malt agar. | For hyphal growth experiments. |
| <i>Pichia anomola</i> | Malt agar or GYEP agar or broth. (GYEP broth is 10% glucose, 1% yeast extract, 1% peptone. Add agar to solidify if required.) | A yeast that can be used to produce a fragrant ester or can be used in a microbial fuel cell [see page 1], but without the need for a mediator (methylene blue) as it transfers electrons directly to the electrode. |
| <i>Saccharomyces carlsbergensis</i> | Malt agar or GYEP agar or broth [see recipe above]. | Useful for comparing the ability of different yeast species to metabolise different sugars. <i>S. carlsbergensis</i> can use raffinose for anaerobic fermentation while baker's yeast, <i>S. cerevisiae</i> , cannot. |
| <i>Saccharomyces cerevisiae</i> STRAIN K5-5A | Malt agar or GYEP agar or broth [see recipe above]. | An unusual yeast strain that is red in aerobic conditions but white in anaerobic ones. |
| <i>Saccharomyces diastaticus</i> | Malt agar or nutrient agar with 1% (w/v) starch added. | Makes the enzyme amyloglucosidase (AMG), which breaks down starch. |

Maintenance of slope cultures

Storage

Microbial slope cultures should generally be stored at room temperature, in the dark. They can be kept like this for up to 12 weeks, after which the microbes should be subcultured onto a new slope to ensure that you maintain a culture of viable cells. Slope cultures should NOT be stored in a fridge.

Streaking out

When you receive the culture, it is good practice to streak it onto a plate, progressively diluting the cells by spreading them out so that there are individual colonies on part of the plate. Stock plates should be prepared by taking cells from these isolated colonies.

Slope cultures, each **£19.00**

■ Plant science

Cauliflower cloning kit (Plant tissue culture)

This kit provides a simple and proven method, devised by the Royal Botanic Gardens, Kew, for plant tissue culture in schools. Callus tissue will be seen in 7–10 days, and small rooted plants can be produced in just 12 weeks. One kit is sufficient for 25 students working individually (or 50 students if the plants are not to be rooted and potted on). *Suitable for GCSE, A Level and equivalent courses.*

Cauliflower cloning kit £60.00

Replacement parts AS PROVIDED IN THE KIT

MS medium + agar (for 500 mL) £7.35

Kinetin solution, 1.25 mL £7.35

Empty vials for plants (50) £14.70

Students' instruction cards (25)..... *£15.75

* Zero-rated for VAT.

Thin layer chromatography of kiwi fruit chloroplast pigments

This was formerly used as an assessed practical task at A Level. Carried out on a small scale, it requires only small volumes of solvents. Each pack contains microcentrifuge tubes, pipette tips and thin layer chromatography sheets for either 20 or 50 students. You will need to provide suitable solvents, glass vials (such as universal bottles) and kiwi fruit. Please see the method on the NCBE web site. *Suitable for A Level and equivalent courses.*

Kiwi TLC pack 20

(Contains 6 sheets, each 5 cm x 20 cm) £25.00

Kiwi TLC pack 50

(Contains 14 sheets, each 5 cm x 20 cm) £38.00

www.ncbe.reading.ac.uk

Antibiotic production and test cultures

This pack comprises a slope culture of *Streptomyces griseus*, which produces the antibiotic streptomycin, plus slope cultures of three microorganisms that it can be tested against (*Bacillus subtilis*, *Micrococcus roseus* and *Saccharomyces carlsbergensis*). The entire test can be done using just a single Petri dish of glucose nutrient agar per student or pair of students. Full instructions are provided. *Suitable for A Level and equivalent qualifications.*

Antibiotic production and test cultures £54.00

T4 bacteriophage and B strain of *E. coli*

As required for some BTEC courses. Provided with instructions for maintenance.

Slope culture of *Escherichia coli* STRAIN B £19.00

Vial of T4 bacteriophage, 450 µL Not currently available

Photosynthesis kit

This kit is based on one developed by *Science & Plants for Schools*. It allows students to carry out quantitative investigations of photosynthesis using algae immobilised in calcium alginate. *Suitable for GCSE, A Level and equivalent courses.*

The kit contains: 8 full-colour Students' Guides; 1 Teacher's Guide; 15 syringe units; 75 bijou bottles; 6 light filters, each ~13 x 20 cm (red, green, blue and 3 different Neutral density filters); 4 g sodium alginate; 3 g enrichment medium; 10x hydrogencarbonate indicator (250 mL); culture of *Scenedesmus quadricauda*. [Note that the algal culture can be stored for many months in a fridge until required.]

Photosynthesis kit £90.00

Replacement parts AS PROVIDED IN THE KIT

Hydrogencarbonate indicator, 250 mL (10x)..... £13.65

Filters, 6 £14.70

3 g enrichment medium..... £11.55

Photosynthesis kit Student's guides 8 *£14.00

* Zero-rated for VAT.



Enzymes for education

These liquid enzyme preparations all come from microbial sources. Depending upon the enzyme, they will retain their stated activity for 3–12 months if they are refrigerated at 3–5 °C. Additional information about the enzymes, including how to use them in the classroom, is available from the NCBE's web site.

Please note that the NCBE supplies these enzymes to schools and colleges for educational use. Commercial users of enzymes or those requiring enzymes for research purposes should contact other suppliers.

Alpha-amylase (*Termamyl*®)

Termamyl® is an α -amylase that hydrolyses the α -1,4 bonds in starch, producing glucose and dextrins. *Termamyl*® is *exceptionally* heat-stable: to denature it the pH must be lowered to 3.5 and the enzyme must be boiled for several minutes. *Contains reducing sugars.*

Amyloglucosidase (AMG)

Amyloglucosidase (also known as glucoamylase) completely converts starch to glucose, hydrolysing both α -1,4 and α -1,6 bonds in amylose and amylopectin. AMG is more heat-labile than *Termamyl*® but it still requires heating to 80 °C for about 5 minutes to denature it. *Contains reducing sugars.*

Cellulase (*Celluclast*®)

Celluclast® will break down cellulose into glucose, cellobiose and longer chain glucose polymers (dextrins). In the school laboratory, its activity can be tested by adding it to a solution of carboxymethylcellulose (CMC) and measuring the change in viscosity. This is readily done by timing how long the CMC solution takes to run through a syringe barrel [see *Cellulase Activity Pack* on page 5].

Carbohydrase mix (*Viscozyme*®)

Viscozyme® is a blend of enzymes that will degrade cellulose and related plant materials. It can be used to treat lettuce leaf tissue to produce protoplasts and plant cell mixtures that can be studied under the microscope.

Catalase (*Catazyme*®)

Catazyme® is a fungal catalase. Its activity can be monitored by adding 0.1 mL of the enzyme to 10 mL of 10 vol hydrogen peroxide in a 250 mL measuring cylinder to which 0.1 mL of washing-up liquid has been added. The volume of the foam in the measuring cylinder can be recorded. *Catazyme*® is inhibited by ethanol (you need ~15% ethanol to inhibit the catalase).

Chymosin [rennin] (*Maxiren*®)

Maxiren® is the cheese-making enzyme chymosin (also known as rennin). It is identical to the animal product but is obtained from a genetically-modified dairy yeast. *Zero rated for VAT.*

Invertase (*Bioinvert*®)

Bioinvert® is an invertase obtained from yeast. It breaks down sucrose to glucose and galactose. A standard assay of invertase activity uses DNSA reagent and a colorimeter. Full instructions are given on the NCBE web site.

Lactase (*Lactozym*® 'Pure')

Lactozym® 'Pure' is a preparation of lactase, which hydrolyses lactose to glucose and galactose. Can be immobilised in sodium alginate and used to produce lactose-reduced milk.

Pectinase (*Pectinex*®)

Pectinex® is a mixture of several types of pectinases. It can be used to increase the yield of juice from apples, pears, etc and also to peel citrus and other fruits.

Pectin esterase (*Novoshape*®)

Novoshape® strips $-\text{CH}_3$ groups from pectin, allowing divalent ions (such as Ca^{2+}) to form cross-links between the pectin molecules, causing them to form a gel. The process can be used to thicken fruit purées and to stiffen fruit pieces used in yoghurts and desserts, reducing wastage and improving the quality and of the product.

Protease (*Neutrase*®)

Neutrase® breaks down proteins to peptides. It can be used when preparing crude extracts of DNA. It can also be used instead of trypsin to clarify skimmed milk (use 10 mL of 3% w/v dried skimmed milk powder and add 1 mL of 10% v/v *Neutrase*® solution). If you wish to demonstrate the denaturation of an enzyme by heating, heat the *Neutrase*® to 85 °C for about 2 minutes before use.

Fungal 'rennin' (*Fromase*®)

Fromase® is a fungal protease that is often used instead of animal chymosin for making cheese. The type of *Fromase*® we provide (*Fromase*® XL) is extra thermolabile, so it will denature if it is heated before use. *Zero rated for VAT.*

Detergent enzyme products

These enzyme products are formulated to be used in liquid clothes-washing detergents. Typically, one would add up to 2% by mass of these enzyme preparations to a liquid detergent product, then about 8 g of this liquid would be used per litre of water.

They are also suitable for other educational uses (for example, the lipase is widely used in school investigations using phenolphthalein as a pH indicator to show the production of fatty acids when fats are broken down).

Alpha-amylase (*Stainzyme*®)

Stainzyme® degrades gelatinized (cooked) starch to dextrins and oligosaccharides. It is active in the range 30–100 °C and between pH 7–11. *Stainzyme*® is not very sensitive to pH, but the maximum activity is reached at pH 9.

Alpha-amylase (*Termamyl*® Ultra)

Termamyl® Ultra degrades gelatinized (cooked) starch to dextrins and oligosaccharides. The enzyme is thermostable and works well at temperatures between 30 and 100 °C and between pH 7–11.

Lipase (Lipex®)

Lipex® degrades edible fats and oils to fatty acids and glycerol. It is effective under neutral to alkaline conditions (best at pH 10) and performs across a broad temperature range (30–60 °C).

Protease [low temperature] (Savinase®)

Savinase® can hydrolyse most peptide bonds within a protein molecule. It is active throughout the pH range of interest for most detergent applications, namely pH 8–12 (optimally at pH 10). It functions between 20–60 °C, above which the activity falls rapidly. Its optimal temperature is 55 °C.

Protease [high temperature] (Alcalase®)

Alcalase® can hydrolyse most peptide bonds within a protein molecule. It is active between pH 6.5 and 8.5. It functions between 45 and 65 °C with maximum activity at about 60 °C, above which the activity falls rapidly.

All enzymes are supplied as liquids in 100 mL volumes. All enzymes cost £20.00 per 100 mL.

Washing product enzymes pack

This pack contains 100 mL of each of these liquids: *Savinase*®, *Alcalase*®, *Termamyl*®, *Stainzyme*® and *Lipex*®.

Washing product enzymes pack £75.00

Fruit processing enzymes pack

This pack contains 100 mL of each of *four* enzymes used in processing fruit (*AMG*, *Termamyl*®, *Celluclast*® and *Novoshape*®), plus two bottles of *Pectinex*® for juicing and peeling. This pack also includes a copy of *In a jam and out of juice*, a 20-page, full-colour booklet of background information and ideas for practical investigations.

Fruit processing enzymes pack £94.00

DNSA reagent base

DNSA reagent is used for the colorimetric assay of reducing sugars. Thus it can be used to measure the activity of a wide range of enzymes such as amylase, invertase, cellulase, lactase etc that produce reducing sugars as products of their action.

Although widely known in schools across the world, it is seldom used in UK schools. *Suitable for A Level and equivalent courses that require quantitative measurement of enzyme activity, and the use of a colorimeter.*

Note: You will need to add sodium hydroxide to this reagent base before it can be used. When made up it will produce 100 mL. (Each colorimetric test requires 0.3 mL of this reagent.)

DNSA reagent base, to make 100 mL £24.50

■ Publications**In a jam and out of juice**

A 20-page full-colour guide to practical work with pectinases and other enzymes that are used in the processing of fruit. Includes a 7-page introduction, safety guidelines and four practical protocols. *The protocols are suitable GCSE, A Level or equivalent courses.*

In a jam and out of juice *£7.35

Replacement students' guides

The lambda protocol 8 *£14.00
 Nature's dice 8 *£14.00
 Protein power! 8 *£14.00
 PCR and plant evolution 8 *£14.00
 Bacterial transformation kit 18 *£12.00
 Photosynthesis kit 8 *£14.00

* Please note that all publications are zero-rated for VAT.

■ Gel electrophoresis

Gel electrophoresis is mentioned as a practical activity by all the new A Level Biology specifications. The NCBE's award-winning gel electrophoresis system provides a cost-effective solution enabling all of your students to gain hands-on experience.

How does the modular system work?

There are two parts to the system. All the re-usable items (gel tanks, combs *etc.*) come in a BASE UNIT. The base unit contains *eight* sets of these.

All of the consumable items (agarose, DNA, enzymes *etc.*) are provided in MODULES. The modules' contents vary, but they usually include sufficient materials for 16 students or working groups to carry out the practical work. Full details are given in the description of each module.

Some of the modules are ideal for individual practical projects and all of the contents will keep, if stored correctly, for at least a year.

Power supply

The electrophoresis system can be powered either by *four* nine volt batteries or with a 36 volt mains transformer. One transformer is sufficient to power four gel tanks simultaneously.

How do I decide what I need?

Decide how many base units you need, according to your class and/or working group sizes. Remember that the base unit contains *eight* sets of hardware. Next, choose which module(s) you're interested in. Again, you'll need to order the correct number for your class size(s). The modules also act as 'refill packs', although you can also buy most items individually.

Gel electrophoresis base units and modules

Electrophoresis base unit

This pack contains *eight* sets of the items required for gel electrophoresis:

- 8 NCBE gel tanks
- 8 4-toothed combs
- 8 6-toothed combs
- 8 pairs of red and black wires with crocodile clips
- 8 microsyringe dispensing units (without tips).

Electrophoresis base unit £67.00

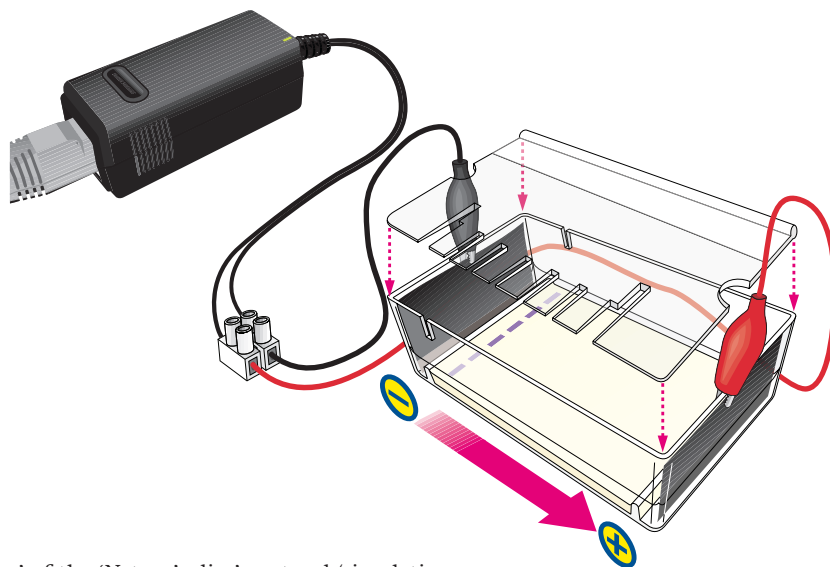

36 volt mains transformer

This is the safe, cost-effective, fast and environmentally-friendly alternative to batteries. With the connector provided, a single transformer can power *four* gel tanks. At 36 volts, the ideal voltage for the NCBE electrophoresis equipment, gels take about two hours to run. *Please note that a standard 3 pin mains lead is also required (similar to those used for many desktop computers, kettles etc).*

36 volt transformer £48.00

Nature's dice

Materials for 2 'runs' of the 'Nature's dice' protocol (simulation of genetic screening), each with 24 students or working groups. Contains: 1 fixed-volume 25 µL micropipette; 25 µg of 1 kb DNA 'ruler'; DNA samples; 48 tubes of restriction enzyme; 48 1.5 mL tubes; 2g of electrophoresis-grade agarose; 100 microsyringe tips; 8 sheets of carbon fibre electrode material; 50 mL of 10x TBE buffer; 8 tubes of loading dye; 50 mL of 2x stain for DNA plus 8 copies of the student's guide and a teacher's guide.

Nature's dice module.....£148.00

The PCR and plant evolution

Contains materials for 16 amplification reactions of chloroplast DNA by the polymerase chain reaction (PCR). This procedure can be carried out using three thermostatically-controlled water baths or a thermal cycler. The amplification takes about 45 minutes after which the samples can be stored before electrophoresis.

The PCR and plant evolution module.....£208.00

Protein power!

Materials for the analysis of 100 protein samples (food proteins). Contains: 100 1.5 mL microcentrifuge tubes; 6 g of protein-grade agarose; 100 'yellow' tips; 8 1 mL syringes; silicone tubing; 8 sheets of carbon fibre electrode material; 50 mL of 10x TB buffer, 50 mL of Laemmli buffer and 200 mL of colloidal Coomassie Blue stain for proteins. Also contains 8 copies of the 'Protein power!' student's guide plus a teacher's guide.

Protein power module..... £94.00

NEW The DNA Detective

A crime scene investigation kit, in which the students get to investigate which of the suspects committed the crime by using DNA analysis. This kit allows students to undertake gel electrophoresis without digesting the DNA first. The kit is designed for 16 groups and provides enough pre-digested DNA for each group to run 6 samples on a gel; giving them all plenty of opportunity to develop the practical skills needed for electrophoresis. Provided in the kit: 8 student guides, 1 teacher/technician guide, 5 tubes of digested DNA (to be aliquoted), 180 µl DNA ladder, 8 tubes of loading dye, 8 sheets of carbon fibre electrode material, 50 ml of 10x TBE buffer, 50 mL of 2x stain for DNA, 2 g of agarose, bag of 100 white tips, bag of 1.5 ml coloured tubes for aliquoting the digested DNA. .

DNA Detective module.....£108.00

The lambda protocol

Materials for two 'runs' of 'The lambda protocol' (restriction of λ DNA), each with 8 students or working groups. Contains: 16 tubes of *Bam*HI; 16 tubes of *Eco*RI; 16 tubes of *Hind*III; 16 tubes of λ DNA; 16 'control' tubes; 2 g of electrophoresis-grade agarose; 300 microsyringe tips; 8 sheets of carbon fibre electrode material; 2 foam floaters; 50 mL of 10x TBE buffer; 8 tubes of loading dye; and 50 mL of 2x stain for DNA. Also contains 8 copies of 'The lambda protocol' student's guide plus a teacher's guide.

Lambda protocol module £133.00

■ Replacement items

Room temperature stable DNA and restriction enzymes

Restriction enzymes and λ DNA in colour-coded tubes containing either 10 μ g of DNA or 10 units of a restriction enzyme dried with buffer and a blue dye. They should be stored dry at room temperature and are supplied with silica gel desiccant.

| | | |
|-----------------------|----------------|--------|
| Lambda DNA | 16 tubes | £23.00 |
| <i>Bam</i> HI..... | 16 tubes | £23.00 |
| <i>Eco</i> RI | 16 tubes | £23.00 |
| <i>Hind</i> III | 16 tubes | £23.00 |

Lambda DNA and enzymes pack

16 tubes of each restriction enzyme and λ DNA, with 16 empty yellow tubes.

| | |
|-----------------------------------|--------|
| Lambda DNA and enzymes pack | £84.00 |
|-----------------------------------|--------|

Gel tanks and combs

| | | |
|-------------------------------|---------|--------|
| Gel tanks WITHOUT COMBS | 8 | £23.00 |
| 4-toothed gel combs | 8 | £13.00 |
| 6-toothed gel combs | 8 | £13.00 |

Plasmids for 'Nature's dice'

| | |
|--|--------|
| Plasmid mixtures (3 tubes) as in kit | £44.00 |
|--|--------|

Plasmids for The DNA Detective

| | |
|---|---------------|
| Pre- Digested DNA (5 tubes) as in kit | £34.00 |
| Pre-digested DNA (5 tubes) as in kit + DNA ruler...180 μl.... | £64.00 |

Materials for 'Protein power!'

| | | |
|---------------------------------------|-------------|--------|
| Protein electrophoresis agarose | 6g..... | £17.30 |
| TB buffer + 10% SDS (10x) | 50 mL | £16.00 |
| Laemmli buffer | 50 mL | £18.00 |
| Colloidal coomassie blue | 200mL | £20.00 |

Materials for chloroplast PCR

| | | |
|--|------------|--------|
| Primers (one tube of each) AS IN KIT | £15.00 | |
| FTA® cards | 4 | £30.00 |
| Purification reagent | 6 mL | £12.00 |
| TE-1 buffer | 6 mL | £6.00 |
| 'Ready to go' PCR beads | 17..... | £45.00 |

Other electrophoresis kit items

| | | |
|---|-------------------|--------|
| Empty yellow tubes..... | 16 | £10.00 |
| Carbon fibre electrode material | 1 pack | £10.00 |
| DNA electrophoresis agarose..... | 2 g | £14.00 |
| TBE buffer FOR DNA ELECTROPHORESIS..... | 50 mL..... | £13.00 |
| Toluidine blue stain FOR DNA | 50 mL..... | £11.00 |
| 1 kb DNA ruler (ready-diluted) | 130 μ L | £30.00 |
| Loading dye BROMOPHENOL BLUE | 8 tubes..... | £11.00 |
| Foam tube holders | 3 | £7.50 |

■ Fixed volume micropipettes

These pipettes are accurate, autoclavable and robust. They have a 'double action' like conventional micropipettes, so that the last drop of liquid can be expelled from the tip.

| | | |
|------------------------------|------------------|--------|
| <i>Volac</i> Minipipet | 25 μ L | £24.00 |
| <i>Volac</i> Minipipet | 50 μ L | £24.00 |

Micropipette tips and microsyringes

The white 10 μ L tips are graduated at 2 and 10 μ L and fit the microsyringes; the yellow 100 μ L tips *are not* graduated.

| | | |
|---------------------------------------|-----------|--------|
| Microsyringes | 8 | £32.00 |
| White 10 μ L graduated tips | 300 | £17.00 |
| Yellow 100 μ L tips | 100 | £9.50 |

■ School microcentrifuge

This 12 volt microcentrifuge holds 8 standard (1.5 mL) microcentrifuge tubes, and will spin at up to 13,000 rpm (8,500 g). It has been designed especially for educational use and is supplied with 120 microcentrifuge tubes in assorted colours. *Please note that it requires a 6–12 V variable voltage (1,200 milliamp) DC transformer, which is not supplied. There are several suitable models that can be purchased for approximately £10. You need a variable 6-12 volt (1200 mA maximum) DC mains transformer. Masterplug 1200 mA AC/DC Mains adapter (Model MVA 1200-MP) is suitable and can be purchased from online suppliers such as Amazon.*

| | | |
|--|-----------|-------|
| Microcentrifuge WITHOUT POWER SUPPLY | £89.00 | |
| Microcentrifuge tubes, 1.5 mL | 100 | 10.00 |



Unfortunately this microcentrifuge is not available to schools outside the UK.

■ DNA pendant kit

Extract a sample of DNA from your cheek cells and save it in an attractive unisex pendant. Supplied with 30 full-colour illustrated instruction cards and a photocopyable written guide. Sufficient materials are provided to make 30 pendants. *Please note: each extraction requires a small volume (~2 mL) of ethanol or methylated spirit, which is not provided, as we cannot send this flammable liquid in the post.*

| | |
|-----------------------|--------|
| DNA pendant kit | £83.00 |
|-----------------------|--------|

■ Terms and conditions

Placing an order

For health and safety reasons, we cannot supply goods to residential addresses.

Educational institutions may place an order by email, or post. Our office is open from 08:30 until 14:30 (UK time) from Monday-Friday, excluding public holidays and times when the university is closed. But we will no longer be taking orders over the phone. If you have a query or need technical assistance and would like to speak to someone, then please call 0118 3783743 between 9-11am or 2-3.30pm. Thank you.

Online ordering

If you wish to pay by credit or debit card and are in the United Kingdom, you can place your order via Reading University's online store:

<https://www.store.reading.ac.uk/product-catalogue/national-centre-for-biotechnology-education>

Please note that this service is currently available to schools and colleges in the UK only and that unlike this price list, the online store prices include VAT.

Despatch

Orders are usually despatched within 48 hours of receipt from Monday-Friday. At very busy times there may be a short delay in processing your order.

If the item you have ordered is out of stock and is likely to be delayed for a week or more, we will let you know.

Value Added Tax (VAT)

The prices in this price list do not include VAT. All goods, except those marked with an asterisk (which are zero rated), incur VAT at the UK standard rate.

Orders sent to countries outside the European Union do not incur VAT, but please note that you will be responsible for paying any applicable taxes or duties.

Postal charges

United Kingdom

Except where stated, packing and postage by First Class mail is included in the price of goods within the UK only.

Outside the UK

An additional charge will be made to cover postal costs. Please email NCBE@reading.ac.uk to ask for an estimate of the shipping charge.

Handling charge on non-UK orders

Due to the additional costs involved, we will add a £10 handling charge to all non-UK orders.

Payment

Educational institutions will be invoiced

Official orders with an order number from a school, college or education authority are preferred. All orders will be invoiced.

Payments should be made to the 'University of Reading' in GBP (Pounds Sterling) by cheque or direct bank transfer. Details of our bank account will be included on the invoice we send you.

Credit or debit card payments

If you wish to pay by card, please use our online store.

Non-UK credit card payments

For non-UK educational institutions *only*, we can usually accept credit or debit card payments for orders over £15 (cards with 16 digits only). Please enquire about this by email.

Cancelling an order and returning goods

Occasionally you may wish to cancel an order and return goods to us.

Under the United Kingdom's *Consumer Contracts (Information, Cancellation and Additional Charges) Regulations 2013*, you have the right to cancel the contract for the purchase of most* items within a period of 14 calendar days, beginning on the day after the day on which the goods were delivered to you.

To exercise your right to cancel, you must inform us in a clear statement such as a letter, fax or eMail message.

Full details and a model cancellation form are provided on the NCBE's web site, which you may use if you wish:

<http://www.ncbe.reading.ac.uk/orders>

The Regulations require that the goods must be returned to us in reasonable condition, such that they may be re-sold, within 14 days of your request to cancel.

Please note that you will be responsible for the cost of returning the goods to us unless we delivered the item to you in error or the item is faulty. If the goods are faulty, you have additional rights, notably those granted by the UK's *Consumer Rights Act, 2015*.

When we receive the returned goods, we will refund the purchase price and standard delivery cost. We may make a deduction from the reimbursement for loss in value of any goods supplied, if the loss is the result of unnecessary handling by you.

We regret that we cannot accept the return of perishable items such as microbial cultures, enzymes, plasmids or PCR primers, or bespoke items.

Our contact details

NCBE
University of Reading
2 Earley Gate (TOB 2)
Whiteknights Road
READING
RG6 6AU
The United Kingdom

T : + 44 (0)118 3783743

E : NCBE@reading.ac.uk

W : www.ncbe.reading.ac.uk