

Microbial Fuel cell

DRAFT Teacher's and technician's notes

Introduction

Microorganisms are widely used to produce fuels, such as ethanol (bioethanol) by anaerobic fermentation. Usually, biofuels are blended with conventional fossil fuels such as petrol (gasoline) to produce a fuel that can be used in a conventional, or slightly modified, internal combustion engine. There are limits, however, to the proportion of bioethanol that can be added to petrol without substantial modification of the engine.

In 2013, researchers at the University of Exeter produced genetically-modified *Escherichia coli* that could produce a petroleum substitute that could be used in motor vehicles. In the long term, this could form part of the solution to the need for sustainable fuel supplies. Because it would recycle recently-fixed carbon dioxide (from the plants used to produce the substrate on which the *E. coli* was grown) it would effectively be carbon-neutral, unlike conventional fossil fuels.

Less well-known is the fact that microbes produce electricity directly from the breakdown of organic waste. This phenomenon, which has been known about for over a century, has until recently been largely regarded as a biological curiosity, but there is increasing interest in utilising biological fuel cells as a sustainable and carbon-neutral source of energy.

The production of electricity by microorganisms was first reported in 1911 by Michael Potter, a professor of botany at the University of Durham. In a series of simple yet carefully-controlled experiments, he observed that yeast (*Saccharomyces cerevisiae*) produced electricity when it metabolised glucose or sucrose. [Potter also noted the same phenomenon with *E. coli*, but techniques for culturing bacteria were then in their infancy and he had little success with either *E. coli* or other species of bacteria.]

Potter's 'fuel cell' (Figure 1) consisted of a boiling tube with a cylinder of dialysis tubing suspended in it. A culture of yeast in 10% (w/v) sugar solution was added to the cylinder, and sugar solution alone (without any yeast) was added to the outer boiling tube. A platinum wire electrode was placed in each of the liquids, and the electrodes were connected by copper wire to a galvanometer.

Potter noted that the voltage produced by his cell was never greater than 0.5V, no matter how large the cell or electrodes used were. With only primitive equipment and virtually no knowledge of biochemistry, Potter was unable to take his research any further.

In 1931, Barnett Cohen, from the Johns Hopkins Medical School in Baltimore, connected many small (10 mL) bacterial fuel cells together, generating a total of 2 mA and 35 V. The set-up was so complex, however, that it was not a practical energy source.

We know now that such fuel cells work by diverting some of the electrons from the electron transport chain of microbial respiration to an electrode and external circuit in the cell.

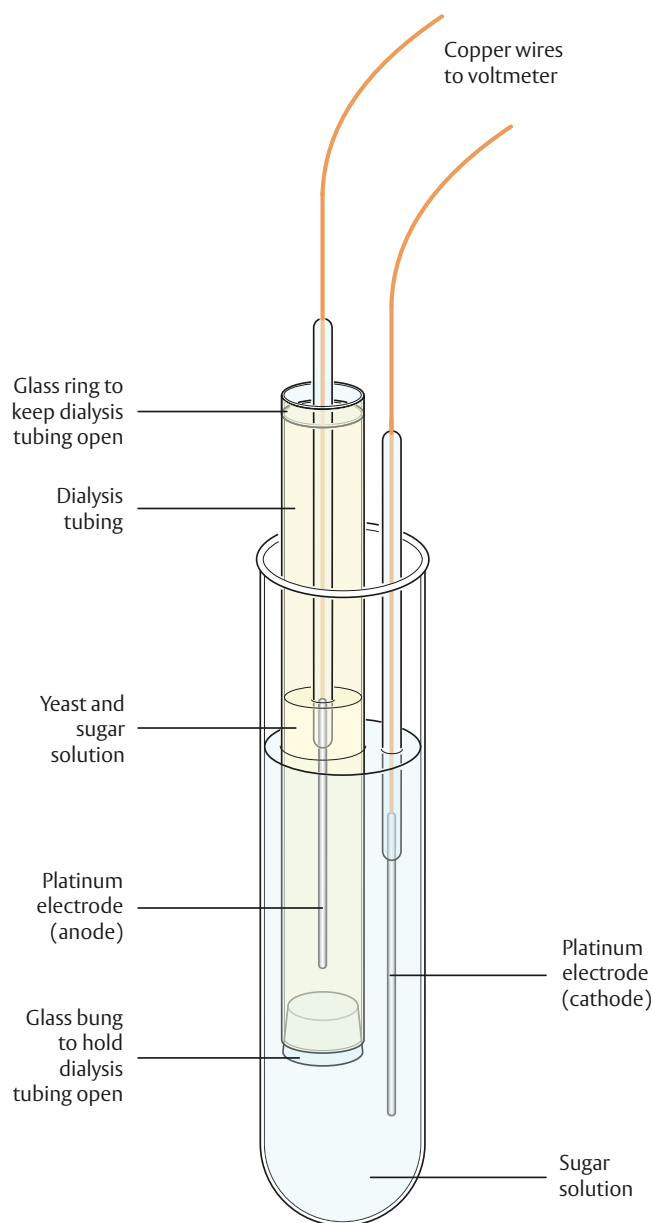

Figure 1: Michael Potter, a botanist, made the first microbial fuel cell more than a century ago.

Make your own Potter fuel cell

If you wish to make a modern version of Michael Potter's original 1911 biological fuel cell, pencil 'leads' or titanium wire are a cheaper alternative to platinum electrodes. (To obtain pencil 'leads', soak a wooden carpenter's pencil in water overnight, and remove the graphite-containing core after the wood has swollen and split.)

A modern electronic multimeter can be used instead of a galvanometer. Knotted Visking tubing can be used in place of Potter's more elaborate set-up. Note that the cell won't work for long, as the small sugar molecules will eventually pass through the dialysis membrane.

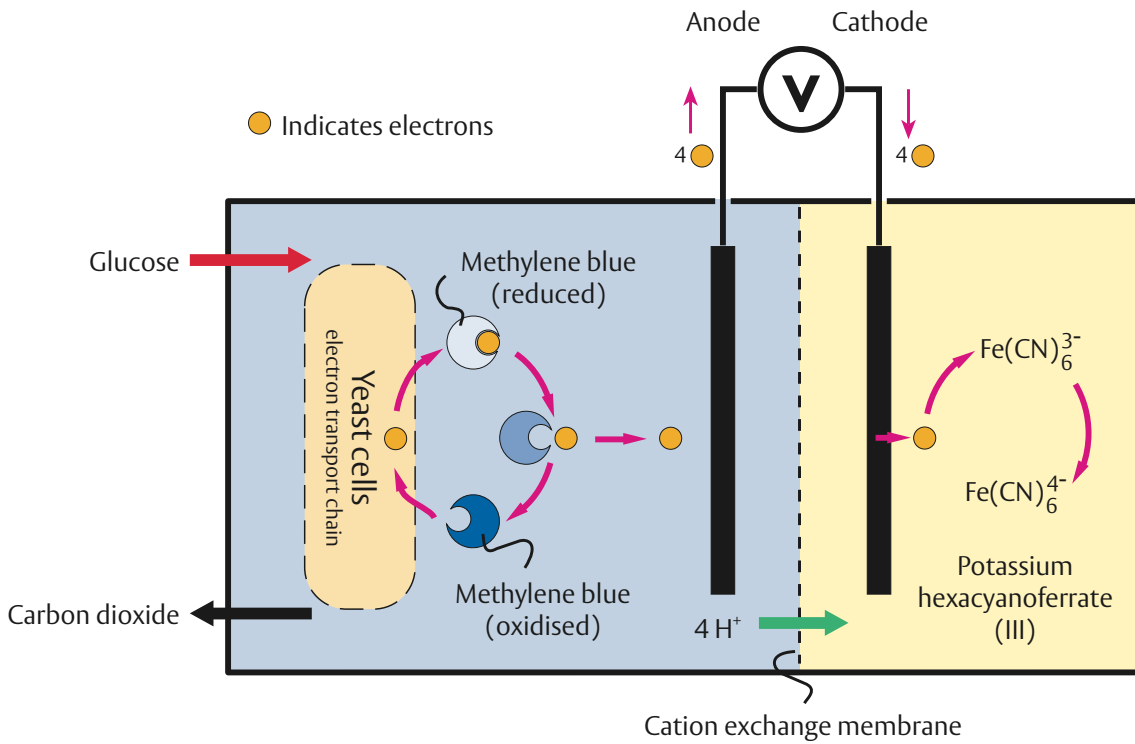

Figure 2: How the microbial fuel cell provided with this guide works.

Mediators

Although research was carried out by Milton Allen in the USA and others in South America during the 1960s, the original work on microbial fuel cells was largely forgotten until the 1980s. It was then that Peter Bennetto and his colleagues at Queen Elizabeth College (now King's College), London injected new life into the subject by researching, designing and building a second generation of microbial fuel cells. Significantly, they utilised 'mediators' (such as methylene blue) to scavenge electrons from the microorganisms' electron transport chain and transfer them to an electrode in the fuel cell (Figure 2). This improved the efficiency of the cells, although the current produced remained small. The reason for this was that the transfer of electrons to the electrodes was inefficient, and the microorganisms only partially oxidise the 'fuel' they consume.

Mediator-less fuel cells

Early in the 21st century several species of microorganism (e.g., *Shewanella putrefaciens*) were found to be able to donate electrons directly to the electrode, without the need for a mediator. Microbes that can do this are collectively called 'electricigens'.

The cell shown in Figure 3 is an example of a fuel cell that utilises such organisms. The anode of the fuel cell is buried about 10 cm deep in the sediment on the sea bed, where there is no free oxygen (that is, in anoxic conditions.) The cathode is positioned in the overlying seawater, where oxygen is available.

The full anode reaction in Figure 3 is:

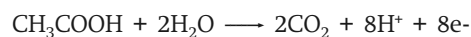

The equivalent cathode reaction is:

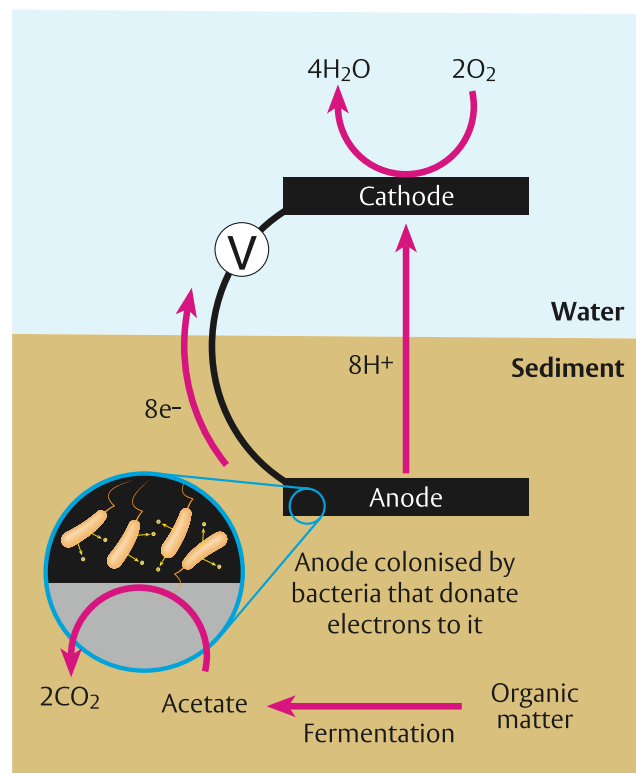
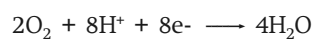

Figure 3: Benthic microbial fuel cell.

Equipment and materials

Each student or working group needs

Straight from the kit

- a copy of the Student's guide [1]
- fuel cell bodies, 2 [2]
- neoprene gaskets, 2 [3]
- bolts with wing nuts, 4
- cation exchange membrane, 1 [4]

Prepared in advance

these three solutions *must* be made up in phosphate buffer — see page 5 of this guide for instructions

- 1 M glucose solution, 5 mL [5]
- 0.02 M potassium hexacyanoferrate (III) solution, 10 mL [6]
- 10 mM methylene blue solution, 5 mL
- 0.1 M potassium phosphate buffer, pH 7.0, 5 mL

Notes

1. Supporting PowerPoint and Keynote presentations are available on the NCBE's web site: www.ncbe.reading.ac.uk/fuelcell
2. These can be glued together if you wish (see page 6).
3. If the fuel cell bodies have not been glued together, four gaskets will be needed.
4. Pre-soak the cation exchange membrane in distilled water at room temperature for at least 24 hours before use. This is to allow for membrane hydration and expansion.
5. The glucose solution should be prepared no sooner than 24 hours before the work is to be carried out, as the solution is not sterile and would therefore support the growth of contaminating microorganisms.
6. The potassium hexacyanoferrate (III) solution is light-sensitive and if it is to be stored it should be kept in a light-proof bottle or in a bottle wrapped in aluminium foil. It should not be kept for longer than six months.

Also required

- 10 mL syringes (without needles), 2
- J-Cloth® or similar cleaning cloth, 2 pieces to fit inside the fuel cell
- dried baker's yeast (*Saccharomyces cerevisiae*), 2.5 g
- a non-sterile Petri dish lid or base, on which to place the assembled fuel cell
- a glass stirring rod
- a pair of scissors
- electrical leads with crocodile clips, 2
- access to a voltmeter or multimeter, for measuring 0–5 volts
- OPTIONAL: low current motor.
(Low current motors are generally expensive. Suitable motors are available from: www.portescap.com Model 22N28-208E.204 will work with the fuel cell. This motor is also available from other suppliers.)

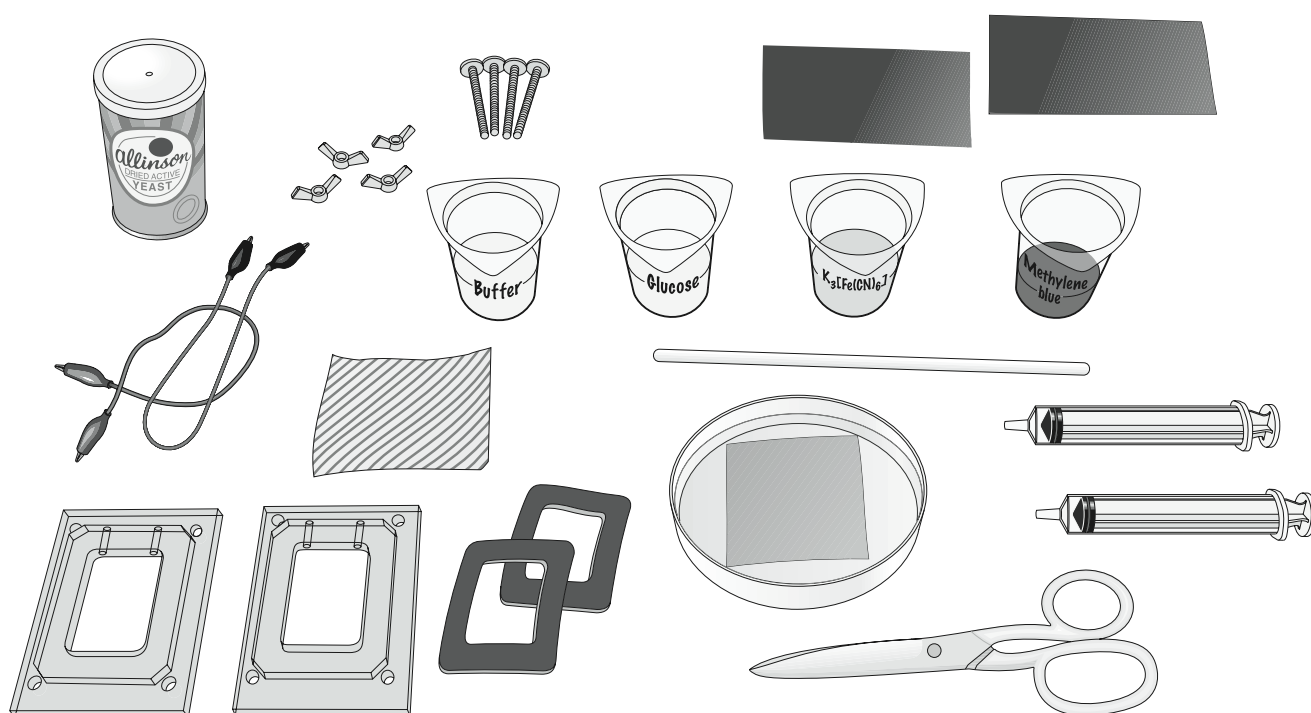

Preparing the phosphate buffer

All of the solutions used in the fuel cell: the glucose, methylene blue and potassium hexacyanoferrate (III), must be made up in 0.1M potassium phosphate buffer, not water.

Make stock solutions

The most convenient way to prepare the potassium phosphate buffer is to make concentrated (1 molar) stock solutions of the two constituent compounds, which can be stored in a fridge, then combined and diluted when required.

Potassium hydrogen phosphate 1M stock solution

1. Dissolve 87.09 g of K_2HPO_4 (potassium hydrogen phosphate) in 400 mL of distilled or deionised water.
2. Make up to 500 mL with distilled or deionised water.
3. Store in a labelled glass bottle in a fridge at 3–5 °C until required.

Potassium dihydrogen phosphate, 1M stock solution

1. Dissolve 68.05 g of KH_2PO_4 (potassium dihydrogen phosphate) in 400 mL of distilled or deionised water.
2. Make up to 500 mL with distilled or deionised water.
3. Store in a labelled glass bottle in a fridge at 3–5 °C until required.

To prepare the buffer

Potassium phosphate buffer, pH 7.0, 0.1M

1. Mix 61.5 mL of 1M K_2HPO_4 stock solution with 38.5 mL of 1M KH_2PO_4 stock solution.
2. Make up to 1 litre with distilled or deionised water. This buffer should be used to make up all of the solutions required for the fuel cell.

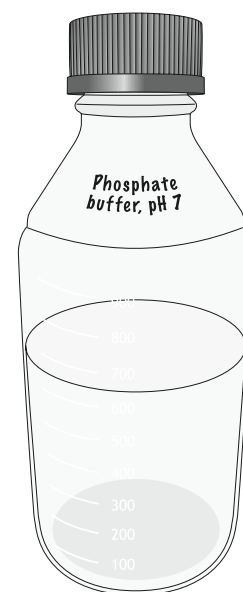

Preparing the solutions

Potassium hexacyanoferrate (III), 0.02 M

1. Dissolve 3.39 g of potassium hexacyanoferrate (III) in 500 mL of potassium phosphate buffer (see recipe above).
2. Store in a labelled glass bottle, wrapped in aluminium foil to exclude light, at room temperature until required. The solution should be used within six months of preparation.

Methylene blue, 10 mM

1. Dissolve 1.87 g of methylene blue in 500 mL of potassium phosphate buffer (see recipe above).
2. Store in a labelled glass bottle at room temperature until required.

Glucose solution, 1 M

1. Dissolve 9 g of glucose in 50 mL of potassium phosphate buffer (see recipe above).
2. Use immediately or within 24 hours of preparation as the solution is not sterile and will support the growth of contaminating microorganisms.



Preparing the fuel cell parts

Each compartment of the fuel cell is made of two *Perspex*[®] parts. Four neoprene gaskets are provided that can be sandwiched between the parts to prevent leaks from the cell.

If desired, however, the two parts that make up each compartment can be stuck together using clear silicone sealant (see picture on the right), so that only two gaskets will then be needed on each side of the cation exchange membrane.

Clear sealant used for bathroom fittings such as shower cubicles is suitable and is available in small *e.g.*, 70 mL tubes.

IMPORTANT. There is a right and a wrong way of joining the fuel cell parts. The top of the fuel cell has a narrower part above the two holes for the bolts. This is so that syringes (without needles) may easily be inserted to fill the fuel cell chambers.

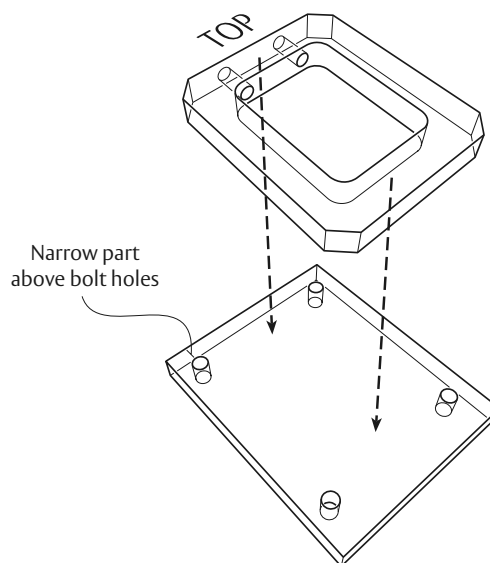

Assembly of the fuel cell

1. Before you start to assemble the fuel cell, rehydrate the dried yeast in potassium phosphate buffer, pH 7.0. To do this, add 2.5 g of dried yeast to 5 mL of buffer solution and stir to produce a thick slurry.
2. Next add 5 mL of 1M glucose solution to the yeast slurry and stir well to mix. *Don't be tempted to rehydrate the yeast in the glucose solution or to mix the glucose solution with the phosphate buffer before adding the yeast — if you do this, the yeast will not rehydrate as readily.*
3. Put the yeast suspension to one side, then cut out and fold two carbon fibre electrodes as shown in the picture on the right.
4. Insert one electrode into each chamber of the fuel cell. *Assemble the two halves identically, so that when they are held together, there will be room to insert a syringe into one of the small holes over each chamber.*
5. Cut out two pieces of J-Cloth[®] or similar non-woven fabric — one to fit into each chamber of the fuel cell. Place one in each chamber on top of the electrodes. *The purpose of the J-Cloth[®] is simply to prevent the electrodes from touching the cation exchange membrane.*
6. Place a neoprene gasket on each half of the fuel cell, then place the two halves together with the cation exchange membrane sandwiched between them.
7. Pass the four bolts through the holes in the outer parts of the cell and tighten the wing nuts. *Do not over-tighten the nuts, as this may distort the cell and allow liquid to weep out.*
8. Stand the assembled fuel cell on a Petri dish base or lid to catch any liquid that leaks from the cell.
9. Add 5 mL of 10 mM methylene blue solution to the yeast suspension. Stir well, then syringe the mixture into one chamber of the fuel cell.
10. Use a clean syringe to add ~10 mL of 0.02 M potassium hexacyanoferrate (III) solution to the other chamber of the fuel cell.
11. Connect a voltmeter or multimeter to the electrode terminals using crocodile clips. *Fuel cells of this type typically generate 0.4–0.6 V and 3–50 mA. A current should be produced immediately — if the meter registers zero, check the connections and ensure that the carbon fibre electrodes are not touching the cation exchange membrane.*

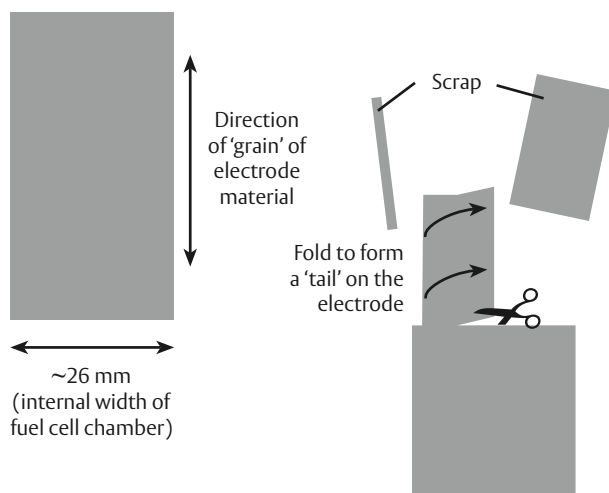

Safety and disposal

Microbiological safety

The fuel cell is designed to be used with baker's yeast (*Saccharomyces cerevisiae*). If other microorganisms are used in the cell, an appropriate risk assessment should be made and good microbiology laboratory practice should be followed.

The cation exchange membrane will melt if it is autoclaved. Therefore if you wish to sterilise the membrane, you will need to use chemical methods.

Because the glucose solution used in the cell is not sterile, it could support the growth of microorganisms if prepared long in advance. The solution should therefore be made up shortly before it is to be used.

Methylene blue

Methylene blue solution can be harmful if swallowed, although it is used at such a low concentration in the fuel cell it is not thought to present a hazard.

Potassium hexacyanoferrate (III)

Potassium hexacyanoferrate (III) is also known as potassium ferricyanide. Although the latter name may suggest that it is toxic, it has a very low toxicity. In concentrated form it can be an irritant to the eyes and skin, although the dilute solution used in the fuel cell does not present a hazard.

Electrode tissue

The carbon fibres comprising the electrode tissue are bound with PVAc (polyvinyl acetate), which is also known as 'wood glue' or 'school glue'.

The tissue may release small fibres, which can cause skin irritation if you handle the tissue a lot. Wear protective gloves if you find the tissue unpleasant to handle. The fibres are biodegradable.

Disposal of reagents

Provided it has been used only with yeast, and not left for too long after use, the fuel cell may be opened under running water and the liquid contents washed away with plenty of water into a foul water drain.

If, in contrast, the cell has been used with other microorganisms, or left for a day or more after use so that it may be contaminated, it should be opened in a bucket of a suitable disinfectant *e.g.*, Virkon® and left overnight (for about eight hours) before the liquid is disposed of, again diluted with plenty of water down a foul water drain.

The cation exchange membrane can be reused and with care it should last for several years. It should be stored in a bottle of distilled water to prevent it from becoming brittle. The membrane should be replaced if small holes appear in it (hold the membrane up to a light to see these).

The carbon fibre electrodes and pieces of J-Cloth® should be disposed of in the normal (non-recyclable) waste.

Additional investigations

Bennetto (1990) gives many suggestions for simple investigations that are suitable for project work in a school laboratory. A few ideas are listed below, but for further details, please refer to Peter Bennetto's paper.

- Several fuel cells may be joined together to give a greater voltage; the current produced will remain the same however. Conversely, increasing the size of the cell (or the electrode area) will increase the current generated but not the voltage.
- Different types of yeast *e.g.*, wine-makers' or bakers' yeast may be used. As mentioned on page 4 of this booklet, some organisms donate their electrons directly to the fuel cell electrode, *without* the use of a mediator such as methylene blue. The yeast *Pichia anomala* has the ability to do this, as does the bacterium *Shewanella putrefaciens*.

IMPORTANT: it is essential to follow good microbiology laboratory practice when handling microorganisms, and to sterilise the cell after use (e.g., by immersion in Virkon® solution). Shewanella has been known on rare occasions to cause infection.

- Mediators other than methylene blue can be used in the fuel cell. You could try using other thionine dyes, such as Azure A, Azure B or Toluidine blue O. Tetrazolium salts or Resazurin may also prove effective. (The suitability of such dyes can initially be tested as suggested by Bennetto (1990)).
- Investigate the effect of temperature on the action of the fuel cell (remember to consider what 'controls' are necessary when making comparisons of this type).
- Investigate the effect of using different sugars in the fuel cell *e.g.*, sucrose or glucose.

Further information

General reading

Bennetto, P. (1987) Microbes come to power *New Scientist*. 16 April (114) 36–40. This article, which summarises the state of the art in the mid-1980s, can be found in Google books. N.B. In this article NAD/NADH has been erroneously represented as a mediator.

Bennetto, H.P. (1990) Electricity generation by microorganisms. *BIO/technology Education*. 1 (4) 163–168. A facsimile of this article is available on the NCBE's web site: www.ncbe.reading.ac.uk/fuelcell

Sell, D. (2001) Bioelectrochemical fuel cells. In: *Biotechnology. Volume 10: Special processes* (Second edition) Rehm, H. J. and Reed, G. [Eds] Frankfurt am Main: Wiley-VCH. ISBN: 978 3527283200. A review chapter in a costly book, which may be available through a library.

Logan, B.E. (2008) Microbial fuel cells. Hoboken: John Wiley & Sons. ISBN: 978 0470239483. An authoritative and comprehensive academic text, albeit costly.

Wrighton, K. C. and Coates, J.D. (2009) Microbial fuel cells: Plug-in and power-on microbiology. *Microbe*. 4 (6) 281–287.

Hao Yu, E. (2014) Bug power: Microbial fuel cells. *Microbiologist*. 15 (2) 10–14. Brief feature on the use of microbial fuel cells to clean waste water and generate electricity.

Scientific papers

Potter, M.C. (1911) Electrical effects accompanying the decomposition of organic compounds. *Proceedings of the Royal Society B*. 84 (517) 260–276. This historical document, describing the first ever microbial fuel cell, is available on the web.

Cohen, B. (1931) The bacterial culture as an electrical half cell *Journal of Bacteriology*. 21, 18–19. This is a *very* brief account of a report given by Cohen to the Annual meeting of the Society of American Bacteriologists. Cohen connected several Potter-type fuel cells together to generate a greater current.

Kim, B.H. *et al* (1999) Direct electrode reaction of Fe(III)-reducing bacterium *Shewanella putrefaciens*. *Journal of Microbiology and Biotechnology*. 9 (2) 127–131.

Chang, I.S. *et al* (2006) Electrochemically-active bacteria (EAB) and mediator-less microbial fuel cells. *Journal of Microbiology and Biotechnology*. 16 (2) 163–177.

Lovley, D. R. (2006) Bug juice: harvesting electricity with microorganisms. *Nature Reviews Microbiology*. 4 (7) 497–508. Review of the state of the art in microbial fuel cells, circa 2006.

Logan, B.E. (2009) Exoelectrogenic bacteria that power microbial fuel cells. *Nature Reviews Microbiology*. 7 (5) 375–381.

Web sites

Moss FM

A photomicrobial fuel cell, powered by moss, produced by researchers at Cambridge University: <http://mosspower.tumblr.com> See also: www.youtube.com/watch?v=YV8nKPdu_Xs and www.cam.ac.uk/research/news/the-hidden-power-of-moss

Logan lab, Penn State University

Bruce Logan and his colleagues at Penn State University conduct research into microbial fuel cells and related technologies. Their web site contains information about their work and useful hints and ideas for those wishing to make their own microbial fuel cells, particularly for student projects: www.engr.psu.edu/ce/enve/logan/

Derek Lovley's home page

Derek Lovley is a microbiologist at the University of Massachusetts, specialising in research into mediator-less fuel cells: www.geobacter.org

Bristol Robotics Laboratory

This research group is a partnership between the Universities of the West of England and Bristol. Ioannis Leropoulos and his team have developed microbial fuel cells that are fed urine and, in sufficient quantity, can charge a mobile phone or provide lighting for a toilet where mains electricity is not available: www.brl.ac.uk/researchthemes/bioenergysustainable/urine-tricity.aspx

iGEM

Several teams entering the iGEM (International Genetically Engineered Machine) competition have made microbial fuel cells. These include Bielefeld University in 2013: <http://2013.igem.org/Team:Bielefeld-Germany/Project/MFC> and Reading University in 2014: http://2014.igem.org/Team:Reading/Fuel_Cell

MudWatt

This company sells a mediatorless 'mud-powered' microbial fuel cell suitable for school projects: www.mudwatt.com

Fuel cell store

An American on-line store that sells almost everything you need for making both microbial and electrochemical fuel cells: www.fuelcellstore.com

Acknowledgements

The type of microbial fuel cell provided with this guide was developed by Peter Bennetto, formerly of the Department of Chemistry at King's College, London. It has been adapted for

school use by John Schollar and Dean Madden at the NCBE. This booklet and the associated Student's guide were written and illustrated by Dean Madden.