

36 V transformer

for NCBE electrophoresis equipment

This transformer is a state-of-the-art AC/DC switching mode power supply. Four gel tanks can be powered simultaneously with the connector provided, without a reduction in performance. Typically, a 0.8% agarose gel will take two hours to run: gels made with a greater concentration of agarose may take slightly longer.

Please note that to use the transformer, you will need a suitable 3-pin mains connection lead fitted with a plug.

Specifications

Input: 90–264 volts AC, 47–63 Hz *via* a IEC-320-C14 port.

Output: 36 volts DC

Safety

The power supply is UL 94V-0 compliant. It meets FCC class B and CISPR class B emission limits and is designed to comply with UL, C-UL, TUV and European CE requirements. The unit is splash proof and has insulation of Class 1 standard.

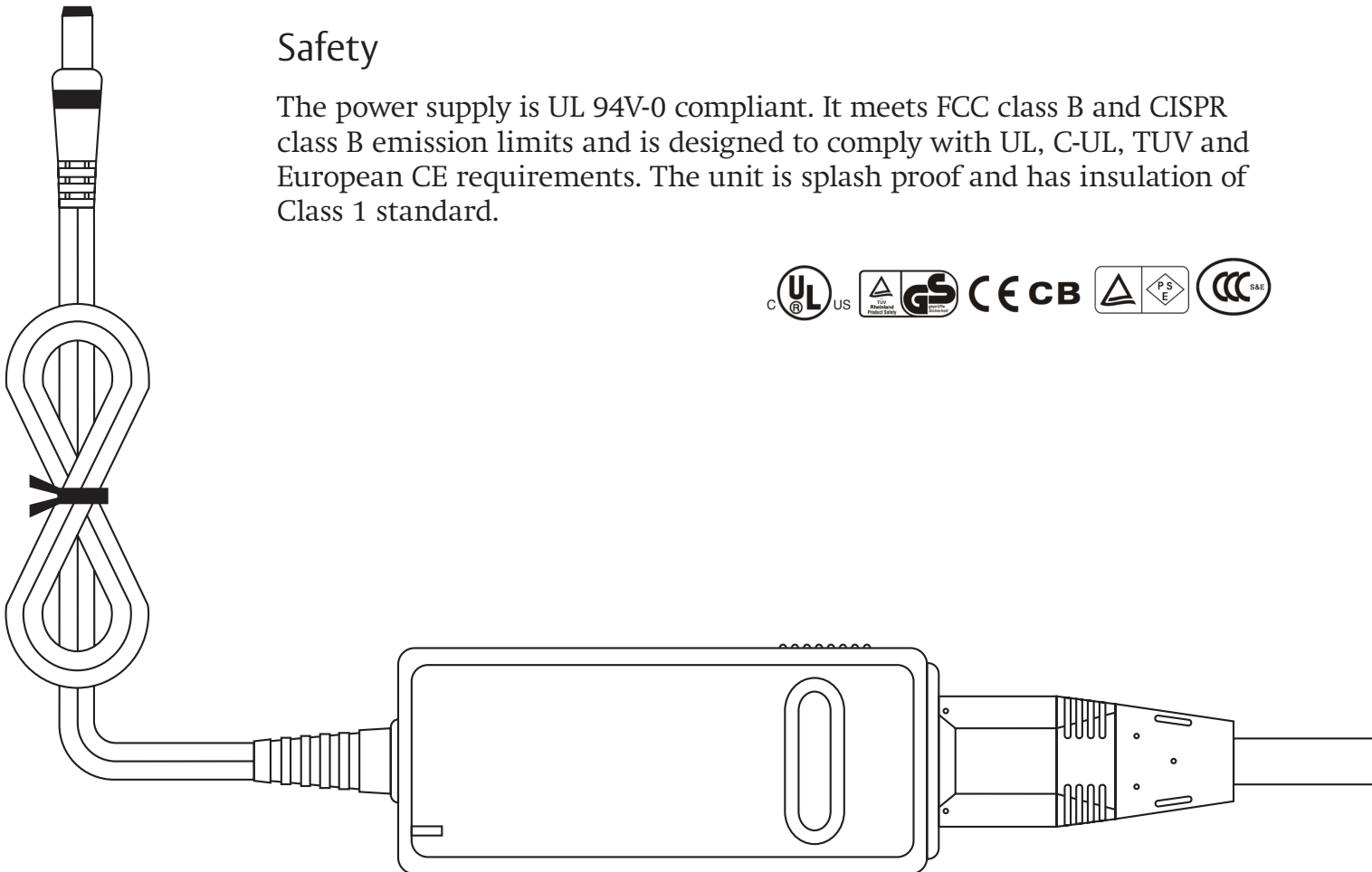

Connecting the transformer to NCBE gel electrophoresis equipment

This modification allows you to connect up to four electrophoresis tanks to one transformer simultaneously.

1. Remove the terminal connector plug from the wire leaving the transformer.
2. Strip about 1 cm of the plastic insulation on both leads to expose the internal copper wires.
3. Attach the cable connector provided to the two bare wires. Insert the wire with white writing on into position P1 on the cable connector. Insert the other wire into position N1 on the cable connector.
4. Attach four red leads (that is, the leads with crocodile clips supplied in the electrophoresis base unit) into position P2 of the cable connector.
5. Attach four black crocodile clip leads into position N2 of the cable connector.

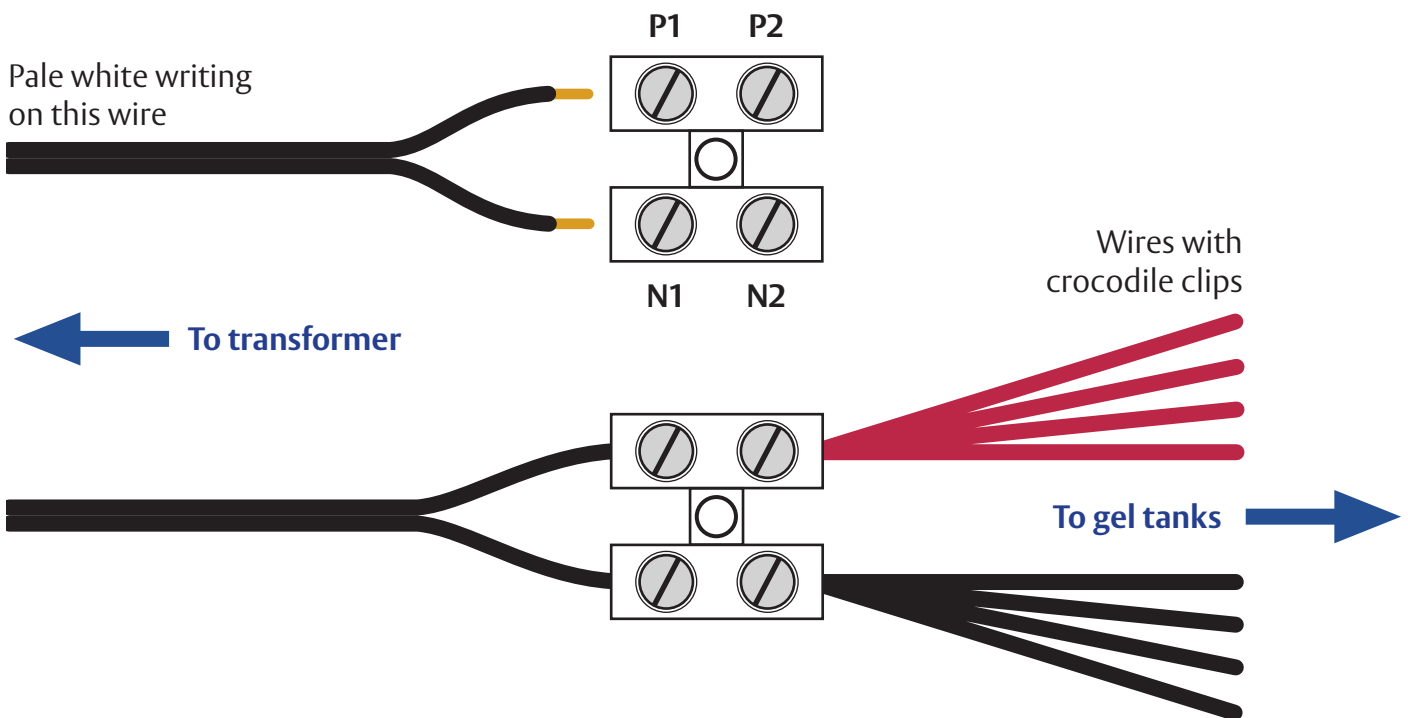

Important

Correct orientation of the cable connector is essential to ensure that the loading dye and DNA migrate through the gel in the correct direction (that is, towards the positive electrode).

Normally, the cable with pale white writing on it should be connected to the red crocodile clip leads, although there may be some variation in manufacture, so is essential to watch the migration of the loading dye the first time you use the transformer. If the dye goes the wrong way in the gel (that is, towards the negative electrode) change the wires over in the cable connector.